

The Cabin Series





Our cabins can be your oasis in the office - a place to reflect, respond and reconnect.

The Cabins provides you with a quiet calm place for private meetings or personal calls. They can even be an office or larger meeting room. Our cabins are unitized meaning you can start with a double unit today and add as many units together as you need - WHEN you need them. Its the ultimate flexibility and customization with 3 - 4 week deliveries.



Ki



Kme



Kwe



*can be extended to 6-8



Kteam



*can be extended to 6-8

The IMT Cabin Series has a slim modern look with rounded corners and clean lines. Front and back vision panels are our standard 10mm tempered glass. Doors close cleanly with our magnetic locks on double acoustically sealed doors. You have a choice of multiple exterior finishes with optional seismic bracing (if required) with no modification to the overall look or function.

IMT Cabin Series Assembly

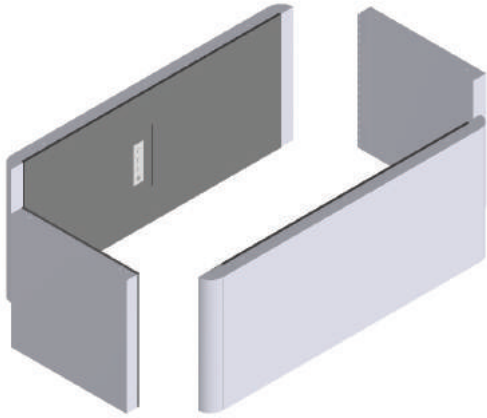

1.

Set all the components on the floor and join together.



2.

Attach the glass back panel.



3.

Attach the front door panel and ENJOY!

The frames are delivered to the site as a pre-manufactured structure ready for assembly and can be easily assembled with just a few flush mounted screws. Hidden lockable casters in the floor structure means that if you assemble it in one place today, you can easily move it to a new location in minutes without specialized tools or hardware. Even the predrilled sprinkler knockout can be removed with a simple hit of a hammer.

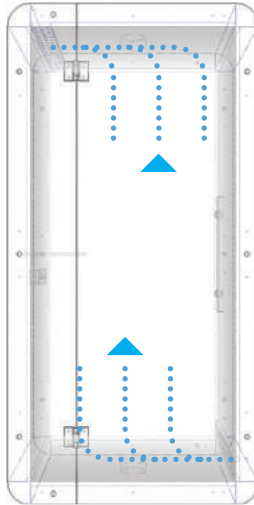

 Ki Ventilation

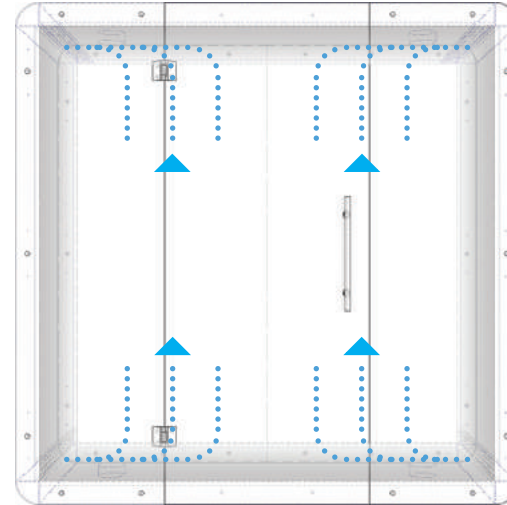

 Kme Kwe Kteam Ventilation

Air is exchanged in each unit from vent openings hidden in the floor and side wall panels. An air circulation system in the ceiling will draw the air through the unit up and out the ceiling panels. The number of vents and fan units increase proportionally as the unit sizes increase and exceeds ANSI/BIFMA standards.

IMT Cabin Finishes



Interior Finishes



Light Grey



Dark Grey



AC54 Ochre



AC37 Royal Blue

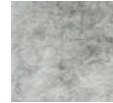

AC03 Silver

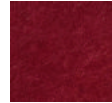

AC17 Burgundy



AC46 Olive

Standard Exterior Finishes



White



Black

Premium Exterior Finishes



P735 Relax Green



736 Ocean Blue



732 Vision Mink



738 Argile Clay



P771 Blue Notte



P761 Fog



P725 Fume

IMT Cabin will suit any environment. Door hardware is available in your choice of Black or Clear Anodized while the ceramic printed edges will always be Black (as shown in the images throughout). In addition to the finishes shown, all IMT standard laminate options are available. Fire Rated exterior finishes are also available if needed.

Wood Exterior Finishes



R60 Fresco



K66 Whisper



K30 Spectra



K60 Chiffon



K16 Esterel

Carpet Colours

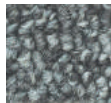

Light Grey

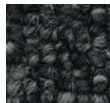

Dark Grey

Aluminum Corners



White



Black



Grey

Door Handles



Black



Silver



IMT Cabin Dimensions

Ki

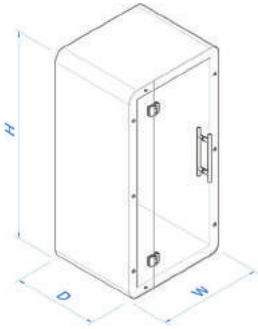

dimensions	overall	inside
height	88"	80"
depth	37"	36"
width	44"	36"

Kme Kwe

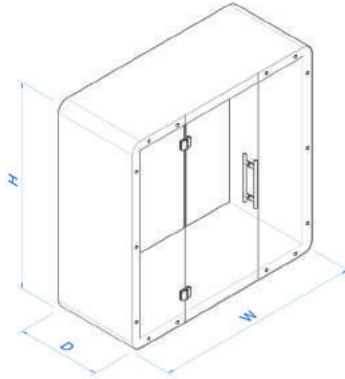

dimensions	overall	inside
height	88"	80"
depth	37"	36"
width	88"	80"

Kteam

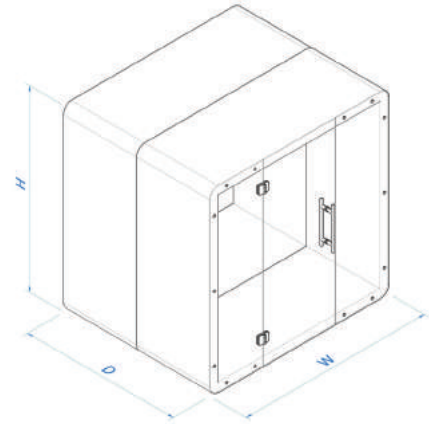

dimensions	overall	inside
height	88"	80"
depth	73"	72"
width	88"	80"

Cabin can be “added on to” as your needs change from the cabin Kme, Kwe Series and upwards. The only limit to how deep you want to make the units is the floor space available.

Private and Soundproof Workspace



IMT offers a quiet space for all to enjoy a productive and peaceful day at work. We offer cabins to fit the needs of any office, lobby, library or convention space and countless other applications. These Cabins offer a quiet space to work, meet or have a phone or virtual conversation. Designed with comfort in mind each cabin will give its user the space and privacy they need to get the job done.



Contact Us Today

 www.i-m-t.com

 info@i-m-t.com

 416-743-4513 | F: 416-743-0132 | 1-844-IMT-1-IMT (468-1468)

 40 Penn Drive, Toronto, Ontario M9L 2A9

Follow us at:

